

# CLOUD CX261 Single Zone Mixer

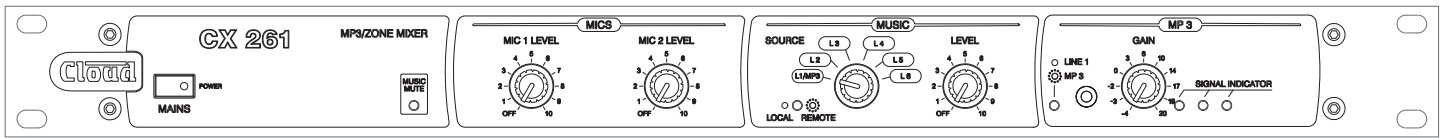

Cloud CX261 - front panel view

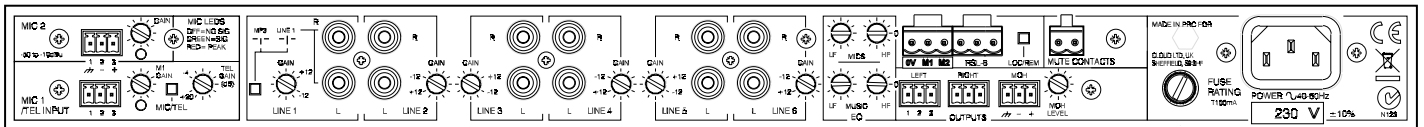

Cloud CX261 - rear panel view

## General Description

The Cloud CX261 is a 1U rack-mounting stereo audio mixer intended for multi-purpose areas where simple control of high-quality background music needs to be combined with a flexible range of paging options.

The CX261 mixes any one of six stereo line inputs with one or two microphone inputs. Separate front panel controls for music source selection, music level and mic levels are provided. Either music level only, or music source and level may be controlled remotely if wished using standard Cloud RL or RSL Series remote control plates. In addition to the main stereo output, there is a transformer-isolated mono auxiliary output which is suitable for providing a MOH (Music On Hold) output to a telephone system. All outputs are balanced at line level.

Line 1's input may be switched (on the rear panel) to an alternative front-panel 3.5 mm jack connector, to permit convenient connection of an MP3 player, laptop or similar portable audio source. A front panel LED confirms its selection. This input is provided with an independent front panel gain control and LED signal level indication.

The CX261 is fully compatible with the Cloud PM Series of paging microphones. The mixer may also be configured to operate with third-party paging systems: either mic input may be enabled via a

simple short-to-ground access connection. This may be bypassed if wished, in which case the mic inputs are always active. A switchable isolating transformer configures MIC 1 input for direct connection to a telephone system, enabling paging messages to originate from an extension. Mic-over-music priority (Automatic Voice-Over) may be selected by internal jumper, and may be triggered either by the access connector or automatically by a mic signal (VOX mode). Additionally, MIC 1 may be set to have priority over MIC 2. Phantom power is available at either mic input (set by internal jumper). Bi-colour LEDs indicating signal level are fitted to the rear panel to aid mic gain adjustment.

Line Input 6 may be set to have priority over any other selected music input to facilitate connection of a jukebox, digital sound store or similar device. One of three release times (up to 12 seconds) may be selected by internal jumper, to unobtrusively restore the original music source.

EQ cards to suit a range of popular installation loudspeakers from various manufacturers may be fitted to either or both channels of the main output. In common with most Cloud products, a Music Mute Input is provided, which may permit compliance with local Fire Authority regulations; the microphone inputs remain active when the Music Mute is applied.

- Versatile stereo mic/line mixer for installed audio applications
- Six (unbalanced) stereo line inputs with individual gain controls
- Two electronically-balanced mic inputs
- Front panel control of music source/level and both mic levels
- Front panel input (3.5 mm jack) for MP3 player, etc., with gain control (overrides rear panel LINE 1 input) and LED level indication
- Separate HF & LF EQ adjustments for music and mic sources
- MIC 1 input configurable as transformer-isolated line input (with separate gain control) for connection to phone system
- MIC 1 priority over MIC 2 (selectable)
- Short-to-ground access connector or VOX-triggered voice-over-music priority on both MIC 1 and MIC 2 inputs

- Selectable LINE 6 priority with choice of release times
- Music Mute control input (N/O or N/C) for interface to emergency system
- Compatible with standard Cloud remote control plates – RL-1 Series (music level) and RSL-6 Series (music level and source selection)
- Electronically-balanced stereo main output
- Mixer can be configured by internal jumper for mono operation
- Transformer-isolated mono auxiliary output for use with telephone MOH systems
- Aux output source selection (internal jumper) – follows main output or always LINE 2
- Optional speaker EQ cards available
- 1U 19" rack mounting unit

All Cloud products are exclusively designed in the UK.

Every Cloud product is exhaustively tested for electronic performance and sonic perfection in Sheffield, England.

## Block Diagram

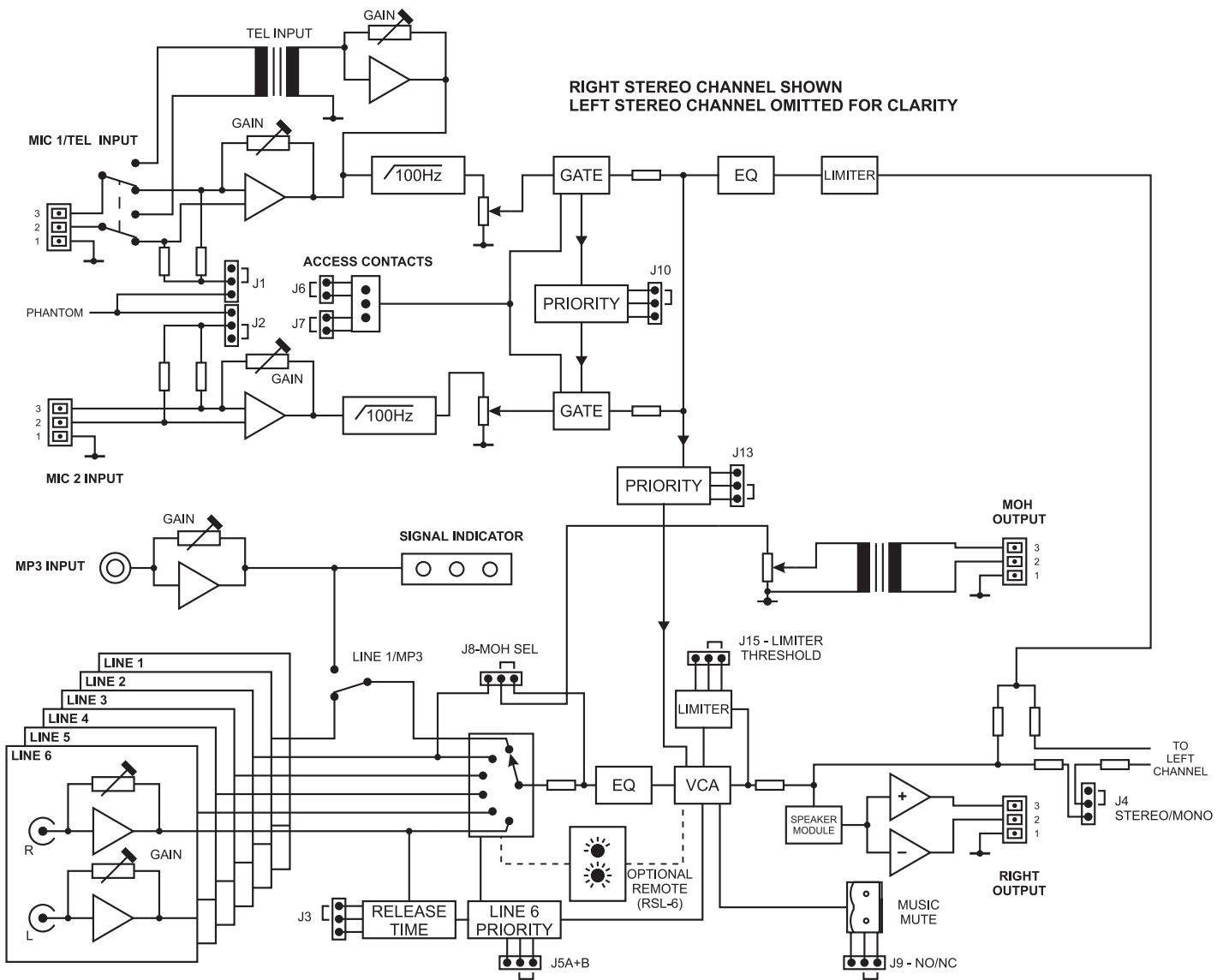

## System Example

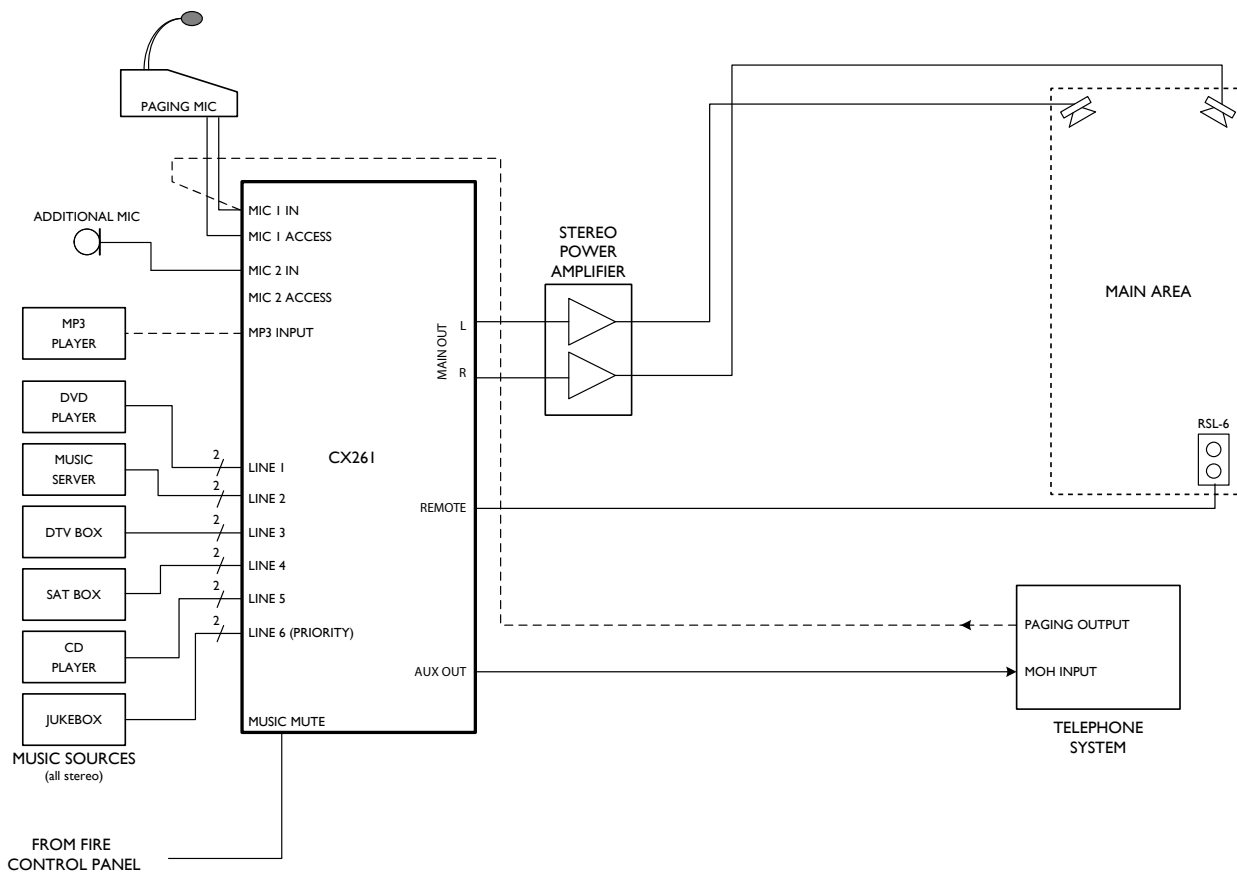

The example shows a CX261 used to provide stereo music, announcements and paging in a multi-purpose area. The area can set its own music source and volume by means of the local RSL-6 remote control plate (optional). Music source and level could be set from the front panel of the mixer itself if preferred.

Paging is achieved using a paging mic such as the Cloud PM1, connected to Mic 1 input; this would typically be located elsewhere in the building. Additional announcements to any zone can be made from the separate microphone connected at Mic 2 input. This could be a second PM1 in a different location if needed.

Six stereo music sources of various types are shown connected; an MP3 player is also shown connected to the front-panel input. (When the MP3 player is plugged in, the DVD player will not be available.) Note that the jukebox is shown connected to Line input 6; if Line 6 Priority is enabled in the mixer, then whenever the jukebox is in use it will always be heard, regardless of the music source setting. This

facility is also useful for connection to a digital sound store to allow pre-recorded announcements to be played.

The Auxiliary Output is used in the example to provide Music On Hold (MOH) to the building's telephone system. The CX261 can be configured so that the music source at this output either follows the currently-selected source or is permanently fed by the source connected to Line Input 2. An additional option would be to connect an audio output of the telephone system (if available) to Mic 1 input; this would permit paging from any suitably-enabled phone extension. In this case, any paging microphone would be connected to Mic 2 Input instead of Mic 1.

Connecting the Music Mute input to the Fire Control Panel will ensure that all music sources will mute should an emergency situation arise.

## Technical Specifications

### LINE INPUTS

Frequency Response	20 Hz - 20 kHz, $\pm 0.5$ dB
Distortion	<0.05% typical, 1 kHz
Sensitivity	0.775 V (0 dBu), $\pm 12$ dB
Input Gain Control	24 dB range
Input Impedance	48 kohms
Headroom	>20 dB
Noise	-88 dB rel 0 dBu (typical); A-weighted, rms
Equalisation	LF: $\pm 10$ dB @ 50 Hz, HF: $\pm 10$ dB @ 10 kHz

### MP3 INPUT

Frequency Response	20 Hz – 20 kHz, $\pm 0.5$ dB
Distortion	<0.05% @ 1 kHz
Sensitivity range	-20 dBu to +4 dBu
Gain adjustment	24 dB

### MICROPHONE INPUTS

Frequency Response	-3 dB @ 100 Hz (filter), $\pm 0.5$ dB @ 20 kHz
Distortion	<0.05%, 20 Hz - 22 kHz
Gain Range	40 dB
Sensitivity	-10 dBu to -50 dBu
Input Impedance	>2 kohms (balanced)
Common Mode Rejection	1 kHz, >70 dB
Headroom	>20 dB
Noise	<-125 dB EIN, A-weighted, 150 ohms
Equalisation	LF: $\pm 10$ dB @ 100 Hz, HF: $\pm 10$ dB @ 5 kHz

### TEL INPUT

Frequency Response	-3 dB @ 100 Hz (filter); <-0.5 dB @ 20 kHz
Distortion	<0.05%, 200 Hz – 20 kHz
Sensitivity	-20 dBu to + 4 dBu
Headroom	>20 dB

### OUTPUTS

Nominal Output Level	0 dBu (MAIN); -6 dBu (AUX/MOH)
Minimum Load Impedance	1.2 kohms (MAIN); 600 ohms (AUX/MOH)
Maximum Output Level	+20 dBu (MAIN); 0 dBu (AUX/MOH)

### GENERAL

Power Input	230 V $\pm 10\%$ (optional external 115/230 V transformer available)
Fuse Rating	T100mA 230V
Fuse Type	20 mm x 5 mm 250V
Dimensions Net (w x h x d)	482 mm x 44 mm (1U) x 155 mm; 19" x 1.7" x 6.1"
Dimensions Gross (Shipping)	560 mm x 140 mm x 290 mm; 22" x 6" x 11"
Weight (Net)	2.15 kg / 4.82 lbs
Weight (Gross)	3.5 kg / 7.7 lbs

## Performance Graphs

### CX261 - Line EQ Curves

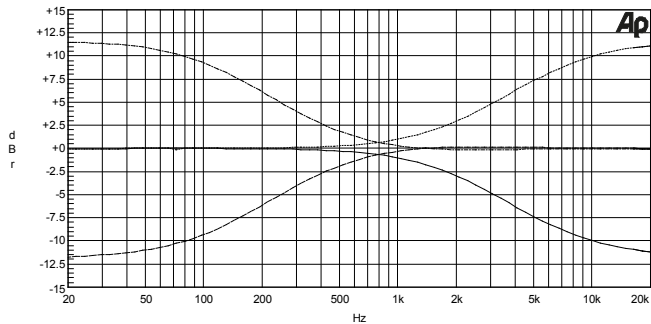

Sweep	Trace	Color	Line Style	Thick	Data	Axis	Comment
1	1	Black	Solid	1	Anlr.Ampl	Left	HF Cut
2	1	Black	Dot	1	Anlr.Ampl	Left	HF Boost
3	1	Black	Dash	1	Anlr.Ampl	Left	LF Cut
4	1	Black	Dash Dot	1	Anlr.Ampl	Left	LF Boost

### CX261 - Mic EQ Curves

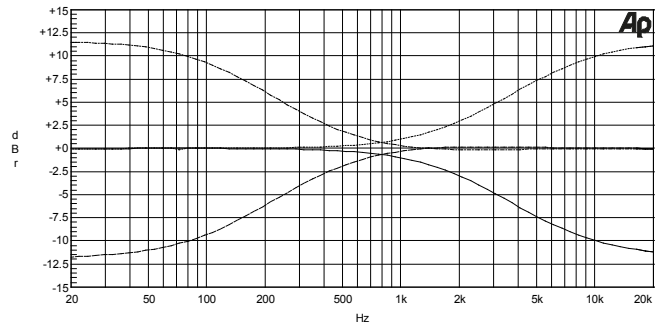

Sweep	Trace	Color	Line Style	Thick	Data	Axis	Comment
1	1	Black	Solid	1	Anlr.Ampl	Left	HF Cut
2	1	Black	Dot	1	Anlr.Ampl	Left	HF Boost
3	1	Black	Dash	1	Anlr.Ampl	Left	LF Cut
4	1	Black	Dash Dot	1	Anlr.Ampl	Left	LF Boost

### CX261 - MOH Frequency Response

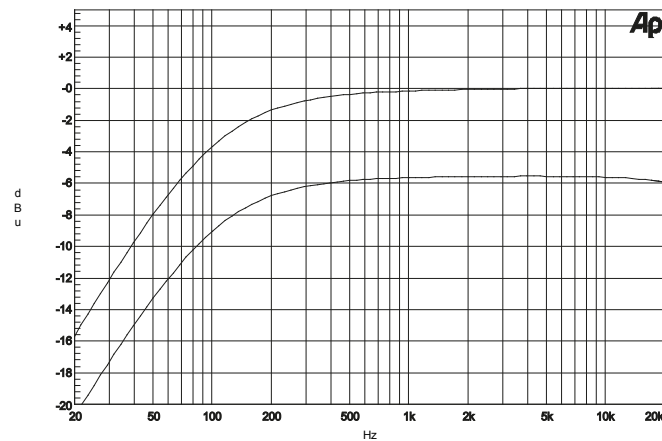

## Architect's and Engineer's Specification

The mixer shall be equipped with six unbalanced stereo music inputs on rear panel phono sockets (RCA jacks) and two electronically balanced microphone inputs on rear panel Euroblock connectors. It shall be possible to select an alternative front panel 3.5 mm stereo jack socket as the input connector for one line input; selection of this input shall be made by a rear panel push-button switch, with front panel LED indication of its selection. The alternative input shall have a dedicated front panel level control and three LEDs indicating signal levels of -20 dBu (green), -4 dBu (yellow) and 0 dBu (red).

The music input to be used shall be selected by a 6-position front panel rotary switch. It shall be possible to control the level of the music source independently of the microphone levels.

The two microphone inputs shall be mixed and summed with the selected music input. Each microphone input shall have its own front panel level control. Each music input and each microphone input shall also have a rear panel sensitivity control; the microphone inputs shall have a bi-colour LED (green/red) to aid adjustment. Independent 2-band equalisation adjustment shall be provided on the rear panel for i) the selected music source and ii) summed microphone inputs. Phantom power shall be available at either or both microphone inputs when selected by internal jumpers.

It shall be possible to configure one microphone input to accept a line-level input directly from a telephone system by a rear panel push-button switch. In this configuration, the input shall be galvanically isolated from the source by an internal transformer, and independent gain control shall be provided.

Control inputs shall be provided to activate either microphone input by external contact closure; it shall be possible to configure the mixer such that this function is overridden and either or both microphone inputs are always active. It shall be possible to configure the mixer to perform the following additional functions: i) when activated by its control input, MIC 1 will take priority over MIC 2; ii) detection of a signal on either microphone input will automatically reduce the music level by 30 dB, iii) one line input will automatically override all others when a signal is present, even if unselected, and a choice of three release times of up to 12 seconds shall be available to restore the original input.

Optional remote control plates shall be available to permit control of music level only or music level and input selection; it shall be possible to retrofit these to the mixer at any time. The remote control plates shall connect via a rear panel Euroblock connector. A push-button switch shall be provided to activate this connector; a front panel LED will confirm activation and the corresponding front panel controls will be disabled. When remote control of music level only is required, it shall be possible to retain front panel control of source selection by moving an internal jumper. An external control input shall be provided to allow muting of the music source by a fire alarm or other external emergency system via isolated, 'volt-free' contacts, and this input shall be configurable to respond to either a short or open external circuit.

The mixer shall have three outputs: main L & R stereo and a mono auxiliary music output. It shall be possible to configure the mixer by internal jumper to combine the L and R signals for mono output operation. The main outputs shall be electronically balanced and the auxiliary output shall be transformer balanced and galvanically isolated so as to be suitable for connection to a telephone system as a Music On Hold source. All outputs shall be on rear panel Euroblock connectors. The auxiliary output shall be configurable internally to either follow the selected music source, or to be permanently fed with a mono sum of one line input; this line input will not be the same one that can be set to have priority over the other line inputs. The microphone inputs shall have no signal path to the auxiliary output. It shall be possible to set the level at the auxiliary output independently of the main outputs with a rear panel control.

A range of optional EQ cards shall be available to optimise the mixer for use with popular installation loudspeakers from various manufacturers. It shall be possible to fit these in either of the channels of the main output.

The mixer shall be built in a 1U steel chassis for mounting in a standard 19" rack. The mixer will be fitted with a front-panel power switch with LED indication. The mixer shall be powered by 230VAC mains, connected via a detachable IEC cable. An optional, external 115/230 V transformer shall be available to allow the mixer to operate on a 115V mains supply.

The mixer shall be the Cloud CX261; the optional remote control plates shall be the Cloud RSL-6 Series (music level and source selection) and the Cloud RL-1 Series (music level only).

### Cloud Electronics Limited

140 Staniforth Road, Sheffield, S9 3HF, England.  
Telephone: +44 (0)114 244 7051 Fax: +44 (0)114 242 5462  
Web: www.cloud.co.uk E-mail: info@cloud.co.uk

### Cloud Electronics USA

2065 Sidewinder Drive, Suite 200, Park City,  
Utah 84060, United States of America.  
Toll Free: 0855 810 0161  
Web: www.cloudusa.pro E-mail: sales@cloudusa.pro